

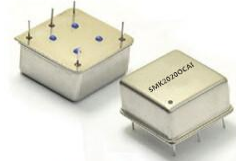

FEATURE

The SMK2020 is the cost effective highly stable oscillator for telecom applications.

Frequencies available are from 5MHz to 500MHz, and power supply options are 3.3V, 5V & 12V.



APPLICATION

Sync E modules

Stratum 3E timing modules

Time and frequency references

Tests equipment

Specification for electrical appliances

● Electrical Characteristics	
Description	Parameter
Oscillator Output	
Nominal Frequency	5~500.00MHz
Output Waveform	Sinewave、HCMOS
Signal [Option] Sinewave	
Level	+5dBm min
Harmonics Suppression	-40dBc max
Spurious Suppression	-70dBc max
Load	50Ω
Signal [Option] HCMOS	
Output High Voltage	V _{OH} : 2.4V min
Output Low Voltage	V _{OL} : 0.4V max
Rise / Fall Time (10%~90%)	6ns max
Duty Cycle	45% ~55%@50%
Load	15pF



Supply Voltage		
Operation Voltage	3.3V±5%、5.0V±5%、12.0V±5%	
Steady Current	500mA max@25°C	
Starting Current	1000mA max	
Frequency Characteristics		
Frequency Tolerance	±0.1ppm max @25°C±3°C	
Frequency Stability over Operating Temperature Range	±1.0ppb max @-20°C~+70°C	
Frequency Stability / Supply Voltage	±3.0ppb max @-30°C~+75°C	
	±5.0ppb max @-40°C~+80°C	
	±3.0ppb max @Vs ±5%	
Frequency Stability/ Load	±3.0ppb max @Load ±5%	
Short Term Stability	0.01ppb @ 1 second tau	
Aging Tolerance Per Day	±0.5ppb max @ after 30 days of operation	
Aging Tolerance 1 Year	±0.05ppm max @ after 30 days of	
Phase Noise (Typical) °C F	10MHz@25	
	Phase Noise	
	10Hz	-120dBc/Hz
	100Hz	-140dBc/Hz
	1KHz	-155dBc/Hz
	10KHz	-158dBc/Hz
100KHz	-160dBc/Hz	
Phase Noise (Typical) °C F	100MHz@25	
	Phase Noise	
	@10Hz	≤ -95dBc/Hz
	@100Hz	≤ -125dBc/Hz
	@1KHz	≤ -155dBc/Hz
	@10KHz	≤ -160dBc/Hz
	@100KHz	≤ -168dBc/Hz
@1MHz	≤ -168dBc/Hz	
Frequency Tuning		
Voltage Control Characteristics	Control voltage Range	0Vdc ~5.0Vdc
		0Vdc ~3.3Vdc
		0Vdc ~5.0Vdc
	Slope	Positive
	Linearity	10% max
	Adjustment Range	±0.3ppm min
Input Impedance	100KΩ min	

Environmental Parameters

Storage Temperature Range: - 55to 105° C

Frequency stability over temperature in still air

Shock: IEC 60068-2-27, Test Ea: 1500G acceleration for 6ms, 3

shocks in each of 3 mutually perpendicular planes

Vibration: IEC 60068-2-6, Test Fc, Procedure B4: 10Hz-60Hz, 1.5mm

displacement, 60-2000Hz at 98.1m/s^2 , 30mins in 3 mutually perpendicular planes at 1 oct/min

Solderability: MIL-STD-202, Method 208, Category 3

Bottom View

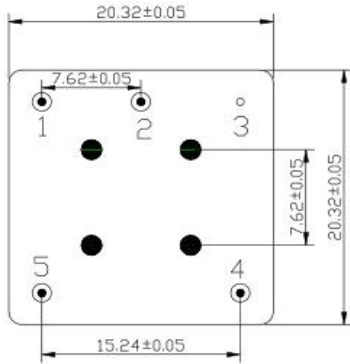

DIMENSION (mm)

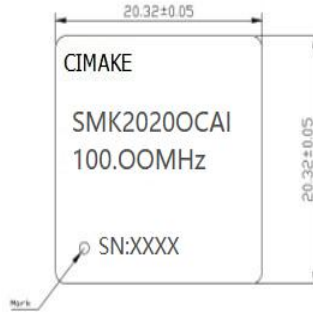

Front View

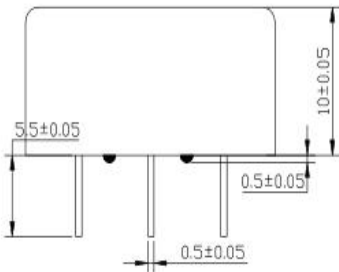

Pin No.	
1	VC/NC
2	Vref/NC
3	Ground
4	Output
5	Supply Votage Input

● Testing circuit diagram

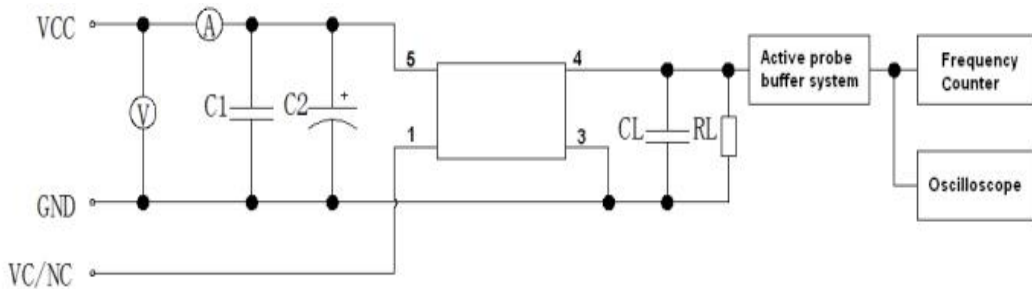

Sinewave: $R_L=50\Omega$, $C_L=NC$;

HCMOS: $R_L=NC$, $C_L=15\text{pF}$;



● Wave Soldering Curve (RoHS)

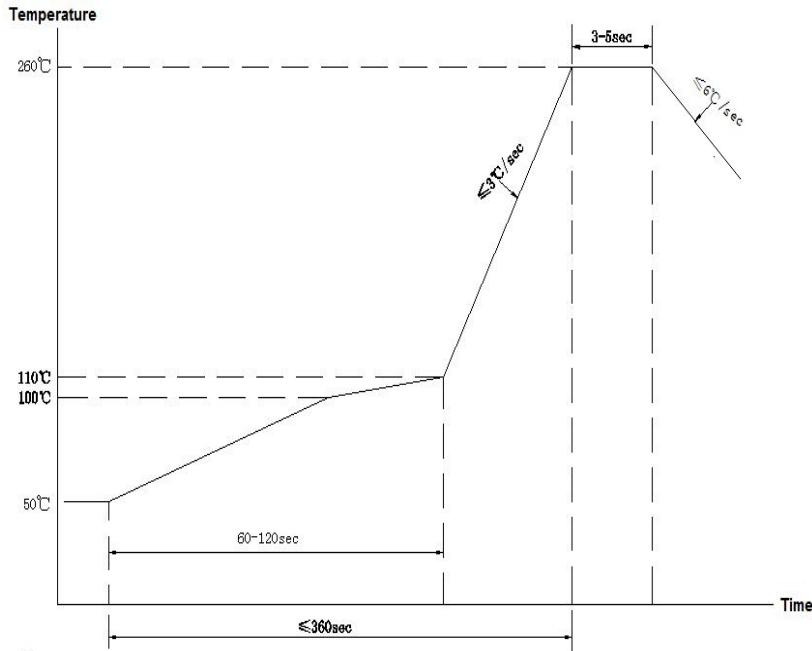

● Type Designation Information

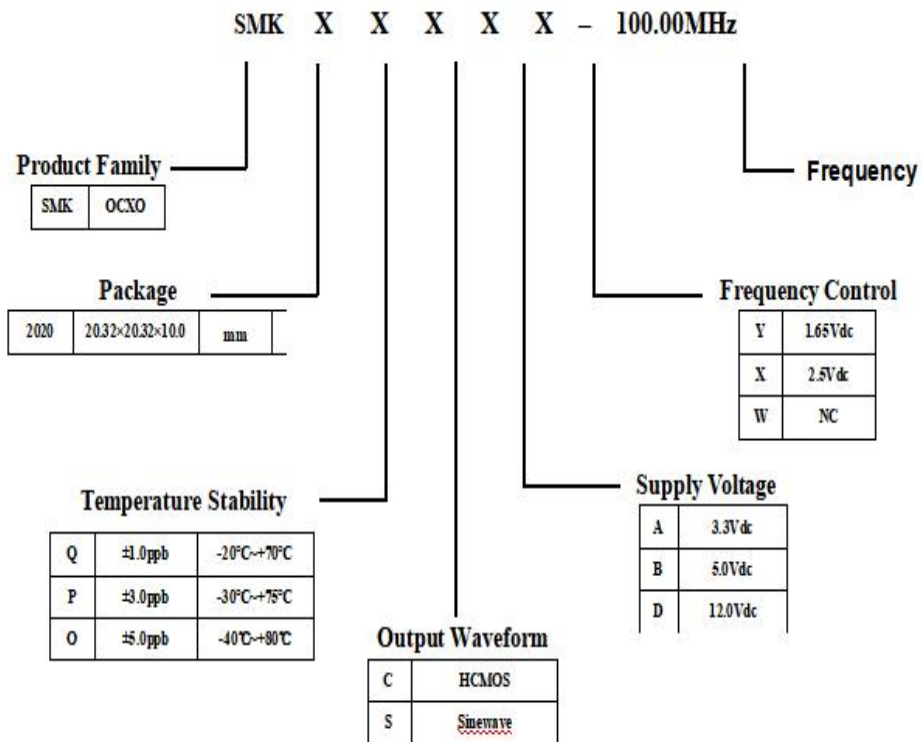

●Type Designation Information

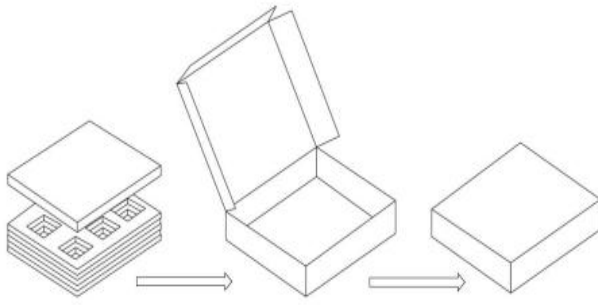

Buffer material

outer packaging box

page:5

EMAIL:info@cimake.net TEL: +0755-26906691 HP:13164746831

B211, Wuhan University Industry-University-Research Cooperation, Yuexing Second Road, Science and Technology Park, YuehaiStreet,Nanshan District, Shenzhen
